

 **OGAWA**

# **NUOVABLAC**

**MASSAGE CHAIR**

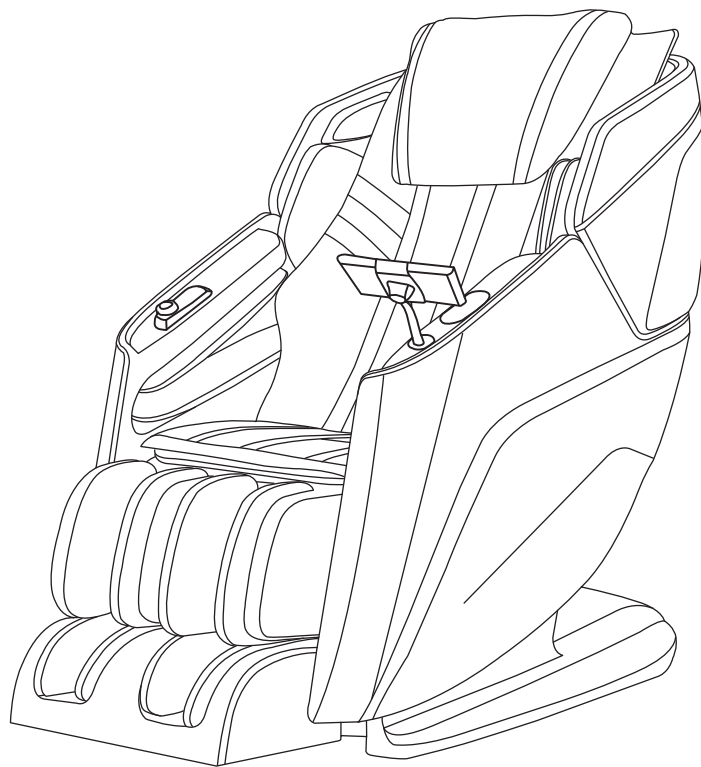

Rev.1.0

User Manual  
YH-7231

# Safety Instructions

## Warning!

The plug must be fully inserted into an appropriate outlet. Improper connection of the equipment-grounding conductor can result in the risk of electric shock.

Check with a qualified electrician and service personnel if you are in doubt as to whether the product is properly grounded. Do not modify the product's accompanying plug. If the outlet is not suitable, be sure to have a proper outlet installed by a qualified electrician.



When using the massage chair, basic precautions should always be followed to reduce the risk of electric shock, burns, fire, or injury.

Read the following details before use:

1. Be sure to insert the massage chair plug into the proper electrical outlet.
2. Make sure that the power plug is securely inserted into the proper electrical outlet to reduce the risk of short-circuit and fire.
3. Always unplug the massage chair from the electrical outlet immediately after use and before cleaning.
4. DO NOT use the massage chair in places where the humidity is high.
5. DO NOT use the massage chair outdoors and avoid places with direct sunlight.
6. If the power goes off during use, be sure to turn the power switch to the OFF position and pull the power plug out from the socket to prevent any damages when the power comes back.
7. Never operate the massage chair if the power cord is wet or damaged.
8. Never plug/unplug the power cord from the socket with wet hands.
9. Close and continuous supervision is necessary when this appliance is used by or near children, invalids or disabled persons.
10. Use this appliance only as described in this user manual.
11. Do not use any attachments other than those recommended by OGAWA.
12. Do not stand, sit or jump in the calves rest when the massage chair is in use. This may result in an accident or injury.
13. Do not attempt to stand on the backrest and armrest .This may result in an accident or injury.
14. Be careful not to fall asleep during the massage.

## Safety Instructions

15. Always keep the massage chair clean and never insert any object into the gaps on and around the massage chair.
16. Do not remove the massage chair by pulling the power supply cord.
17. Be sure to check that there is no one (children in particular), pets or obstacles under the massage chair prior to lowering the leg rest /backrest.
18. Always check whether the surface of the massage chair is torn or ripped before use. If you find any unfamiliar tears in any area of the cloth in the backrest, do not use the massage chair. Kindly contact OGAWA service center immediately for repairs.
19. This appliance is designed for household use only.
20. For those suffering from illnesses, please consult your doctor on whether you can use the massage chair if in doubt.
21. The following persons are requested to consult a doctor prior to use in order to reduce the risk of the user feeling sick or suffering from an injury:
  - Those who have a malignant tumor;
  - Those who suffer from heart disease;
  - Those who are experiencing pregnancy, menstruation and puerperal;
  - Those who require complete rest;
  - Those who are under medical treatment;
  - Those who suffer from back problems or whose backbone is abnormal or bent.
22. If you experience pain during use, stop the massage chair immediately. If any injuries happen, consult a doctor immediately. Never massage on swollen or inflamed parts of the body.
23. This product is a non-professional appliance designed to provide a comfortable massage. Do not use this product as a substitute for medical treatment.
24. Do not use this massage chair for more than 30 minutes at one time and kindly limit the massage to a concentrated area for not more than 15 minutes. Over-massaging can result in overheating, and thus reducing the product's lifespan.
25. Do not operate where aerosol (spray) products are used or where oxygen is being administered.
26. Children shall not play with the appliance.  
Cleaning and user maintenance shall not be made by children without supervision.

- 
- 
- 
27. If the power plug is damaged, it must be replaced by a special plug available from OGAWA or authorized agents.
  28. As a safety precaution , Motor will stop working automatically (for protection) if apply too strong external force during use. Once appear above, switch OFF power ,and switch ON again after 10 seconds . Please pay attention to this ,especially for user whose weight over 100KG.
  29. The appliance has a heated surface. Persons insensitive to heat must be careful when using the appliance.
  30. This appliance can be used by children aged from 8 years and above and persons with reduced physical, sensory or mental capabilities or lack of experience and knowledge if they have been given supervision or instruction concerning use of the appliance in a safe way and understand the hazards involved



## Warranty Claims



1. Warranty is not transferable.
2. This warranty is effective only if the product is purchased from OGAWA.
3. Proof of purchase (original receipt) is required for all warranty repairs.
4. All implied warranties, including but not limited to these implied warranties of fitness and merchantability, are limited to the duration stated in the warranty policy.
5. Damage due to misuse, improper treatment and unauthorized modification and repair are not covered by this warranty.
6. Warranty does not cover accessories and attachments which do not belong to the massage unit.
7. Warranty is not effective to rental, business, commercial, institutional or other non-residential users.
8. All services covered by this warranty must be approved by OGAWA and repaired by authorized technicians only.
9. If replacement parts for defective materials are not available, OGAWA reserves the right to make substitution in lieu of repair or replacement.

# Product Parts

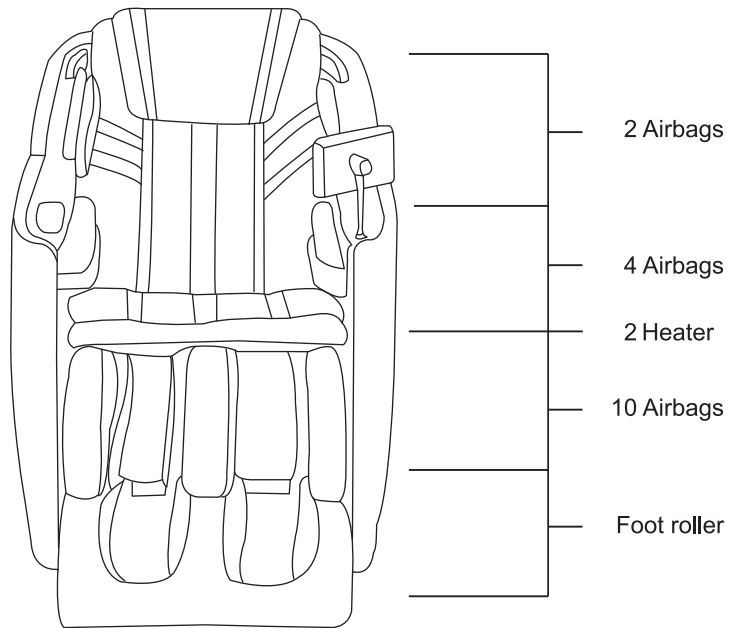
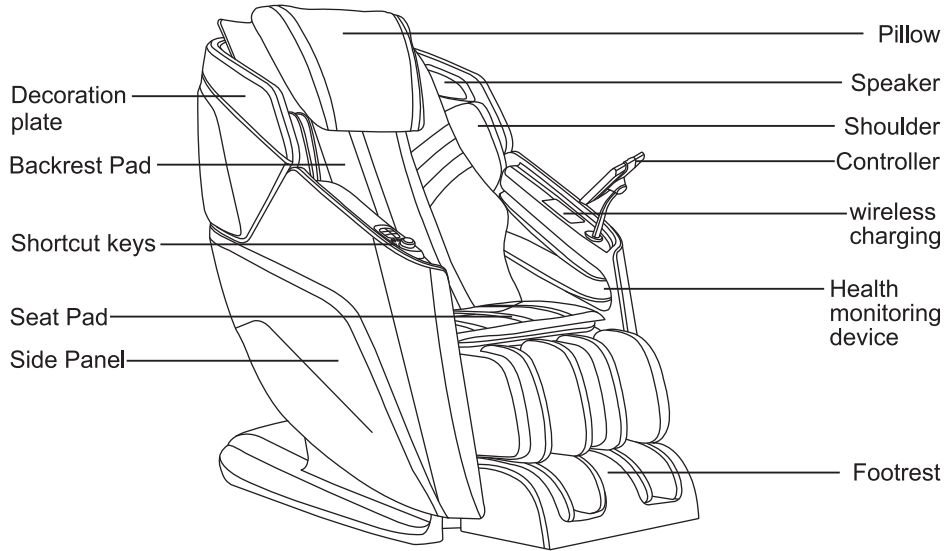

Important-product image or content descriptions may slightly differ due to product quality improvement.

## Controller Diagram

Always press the Power Button to start massage.



**Warning:** Only rated supply 220V must be used to avoid damage to electronic elements.

## QUICK ACCESS CONTROL PANEL

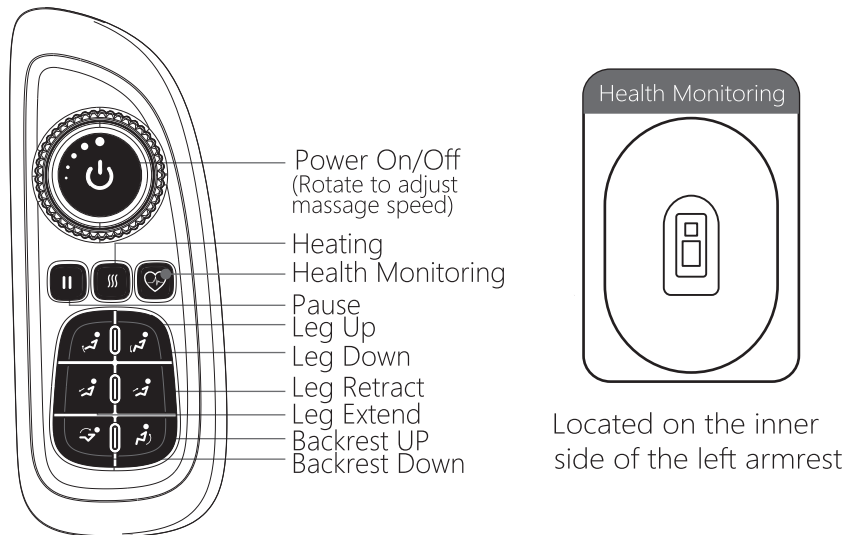







On/Off	Long press to turn the chair ON/OFF.
Pause	Long press to pause massage.
Heating	Long press to turn on the heating function.
Health Monitoring	Long press to turn on the health monitoring function. ( Before use, please insert your fingers into the health monitoring device on the inside of the left armrest )
Backrest Up/ BackrestDown	Long press to adjust backrest.
Leg extend/ Leg retract	Long press to leg extend or retract.
Leg Up/ Leg Down	Long press to adjust legrest.

# Product Operation Guide

## TABLET CONTROLLER INSTRUCTIONS

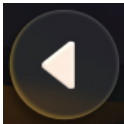



### 1. BASIC KEYS

KEYS	DESCRIPTION	GUIDELINES
	Off	Touch to stop massage and shut off the screen.
	Home	Touch to return to the home page.
	PAUSE	Touch once to halt current massage and countdown timer.
	RESTART	Touch to resume previous massage functions, as well as countdown timer.
	BACK	Touch to return to the previous page.
	ADJUSTMENTS	Touch to <b>ADJUSTMENTS</b> page.
	Air Massager	Touch to <b>AIR MASSAGER</b> page.



# Product Operation Guide



## 2. HOME PAGE MENU

KEYS	DESCRIPTION	GUIDELINES
 AUTO	Auto	Touch to choose from 12 <b>AUTO</b> massage programs. <b>Work Relief, Recovery, Deep Tissue, Rest&amp;Sleep, Thai, Gentle, Athletic, Vertebral, For Her, For Him, Neck &amp; Shoulders, Waist&amp;Hip.</b>
 MANUAL	Manual	Touch to go to the <b>MANUAL</b> massage programs page, choose your preferred massage functions at desired intensities, fully customize your massage.
 ADJUSTMENTS	Adjustments	Touch to go to the <b>ADJUSTMENTS</b> page for zero gravity and massage intensities.
 SETTINGS	Settings	Touch to go to the system <b>SETTINGS</b> page for timer and other preferences.



# Product Operation Guide





## 3. AUTO MASSAGE PROGRAMS

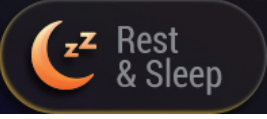

KEYS		GUIDELINES
	Work Relief	This is an exclusive massage program for the workplace, according to the features of long time desk work and business trip, it can ease muscles and recuperate body.
	Recovery	A full body deep massage includes Shiatsu, Knocking and Tapping to ease and relax muscles after surgeries.
	Deep Massage	A full body deep massage includes Shiatsu, Knocking and Tapping to ease and relax muscles after intense exercise, especially promote the body circulation system to improve the muscle recovery after exercise.

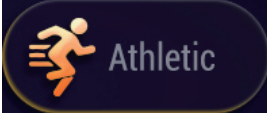
## Product Operation Guide

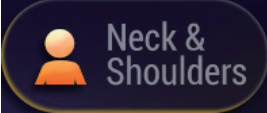

	<p>Rest &amp; Sleep</p>	<p>A program designed to provide a mild massage that is great for deep relaxation. This is the program to help improve the quality of lunch break and sleep. The mild massage kneads body parts from heavy strength to light one, from light to no strength to help soothe tired body gradually.</p> <p>Product features front and rear swing function that takes you into the fantasy space swinging state and a thorough relaxation, best used before going to sleep.</p>
	<p>Thai Stretch</p>	<p>This massage will stretch your calf muscles and hamstrings with a combination of gentle tapping, kneading, rolling, and air compression.</p> <p>This massage is inspired from Thai Massage, the strong kneading and stretch of the body can effectively stretch legs, it's the best choice to relax tired muscles and increase physical vigor.</p>
	<p>Gentle</p>	<p>A full body gentle massage includes Kneading and Heating, designed for daily use.</p>

	<p>For Athletics</p>	<p>An auto programme generated by the system, focus on the tension points collected from athletics, especially promote the body circulation system to improve the muscle recovery after exercise.</p>
	<p>Full Back Massage</p>	<p>A full body massage, mainly focus on your full back with a deep massage that includes air compression to relieve the symptoms of lumbar spine pain.</p>
	<p>Yoga Massage</p>	<p>This is a stretching and relaxation-focused program designed to gently stretch the body, improve flexibility, and relieve muscle tension.</p>
	<p>Leg care Massage</p>	<p>This is a gentle yet effective program designed to pamper and rejuvenate the feet..</p>
	<p>Neck &amp; Shoulders</p>	<p>A full body massage, mainly focus on your neck and shoulders with a slow massage that incorporates soothing heat to relieve neck and back pain symptom. The curve design of the chair backrest makes the massage rollers completely fit the shoulders and the neck, which can effectively relieve fatigue and stiffness.</p>

	<p>Lower Back, Waist and Hips</p>	<p>A full body massage, mainly focus on your lower back, waist and hips with a deep massage that includes air compression to relieve full body pain.</p>
---	-----------------------------------	--

### Backrest Scanning Instructions

A body scan is performed every time the power is on and the user selects an Auto Mode, it is designed to ensure an accurate and personalized massage for every individual. After the power is on, sit on the chair slowly with your back against the chair back, your head against the pillow so the massage sensors can detect your Shoulder Height and the whole back position.

The Tablet Control gives beep sounds when completing a body scan. When micro-adjustment is needed, just touch Roller up/down   , then  to start massage. Make sure the body scan is finished correctly for the best massage.

Once body scan is completed, it will skip to the massage status page without further actions.

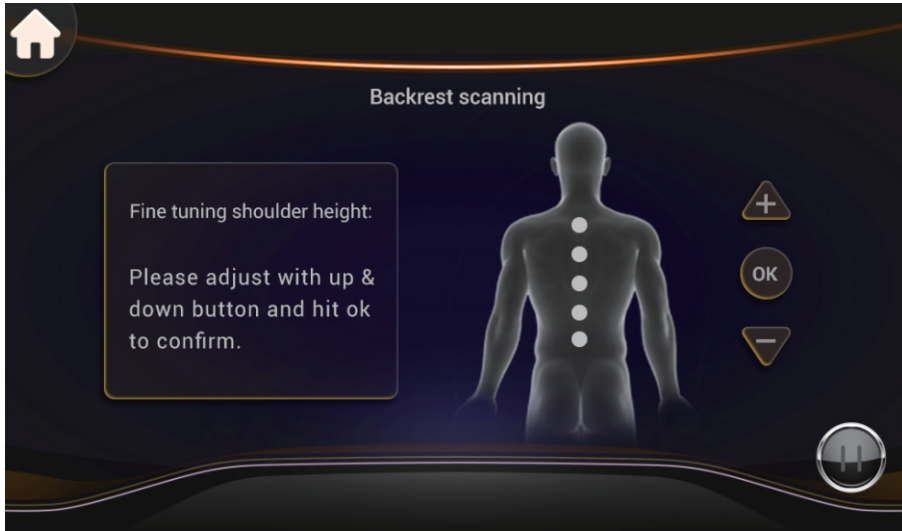

**Note:**

Heating, foot rollers can be turned on/off manually during any auto mode, see below.

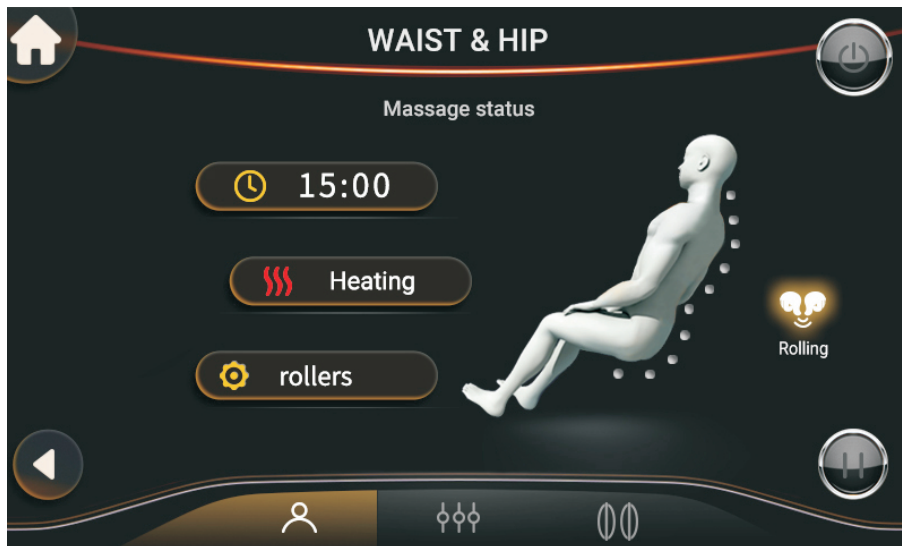





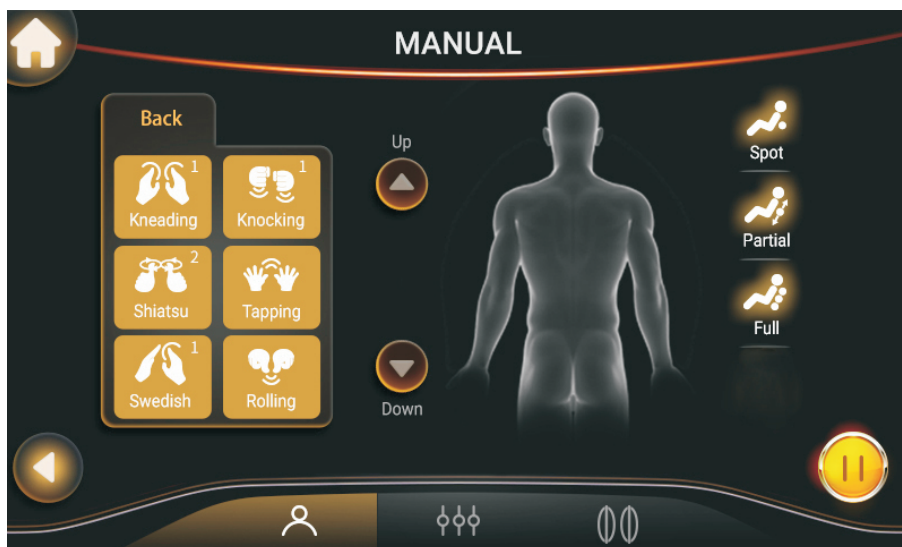

#### 4. MANUAL MASSAGE PROGRAMS

6\*2 massage functions on demand.

**Kneading, Shiatsu, Swedish, Knocking, Tapping, Rolling.**

- Touch to choose a manual massage function for a full back massage at medium strength.
- Manual setting modes can not be combined with other modes.
- The default setting is spot-specific massage with medium width.
- Speed and width are adjustable by touching relative keys.



KEYS	DESCRIPTION	GUIDELINES
 	Roller Spot/ Partial Massage	<p>Touch Spot to activate localized Spot Massage while the original massage mode continues to run at the latest position.</p> <p>Touch Partial to activate Partial Massage, rollers take the latest massage spot position as the center, and will travel approximately 3 inches up or down. Only effective under manual massage mode.</p>
	Full Back Roller	Full Back Massage.
	Roller Width	Every touch will change the massage width interval in the sequence of WIDE>MEDIUM>NARROW. Only effective under manual massage mode.
 	Roller Up or Down	Up or down adjustment.









## 5. ADJUSTMENTS



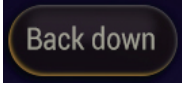



Zero-gravity is based on the NASA space capsule relaxation theory. Using the back, seat, and the leg rest, the chair puts the heart and knee at the same level, reducing the blood circulation pressure. Not only that, but all the gravitational forces can be dispersed to the massage chair, reducing heart and spine pressure.

## Zero Gravity Angle Adjustment

KEYS	DESCRIPTION	GUIDELINES
 	Angle Adjustment Key for Legrest	<p><b>Leg Up</b> Long-press this button, to raise the legrest. Let go of the button to stop raising the legrest.</p> <p><b>Leg Down</b> Long-press this button, to lower the legrest. Let go of the button to stop lowering the legrest.</p>
 	Angle Adjustment Button for Backrest	<p><b>Back Up</b> Long-press this button, to raise the backrest. Let go of the button to stop raising the backrest.</p> <p><b>Back down</b> Long-press this button, to lower the backrest. Let go of the button to stop lowering the backrest.</p>
 	Leg extend or retract	<p><b>Extend Legrest</b> Long-press to extend legrest.</p> <p><b>Retract Legrest</b> Long-press to retract legrest.</p>
	Zero Gravity Function Control	Touch this button to activate the zero gravity position, and choose from Zero Gravity mode 1, Zero Gravity mode 2 and Zero Gravity mode 3.

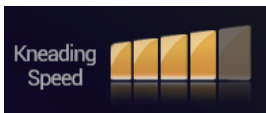
## Other Adjustments

KEYS	DESCRIPTION	GUIDELINES
	Roller Intensity	<b>SLOW / MEDIUM / FAST</b> Only effective under manual massage mode. 
	Kneading Speed	5 levels kneading speed adjustments.
	Tapping Speed	5 levels tapping speed adjustments.
	Air Intensity	5 levels tapping air intensity adjustments.

## 6. AIR MASSAGE



KEYS	DESCRIPTION	GUIDELINES
 Full body	Full body	Full body air massage.
 Shoulder	Shoulder	Shoulder air massage.
 Arm	Arm	Arm air massage.
 Waist	Waist	Waist air massage.
 Leg	Leg	Leg air massage.
 Foot	Foot	Foot air massage.

## 7. SETTINGS



**Note:**

Engineering Mode is for Titan home service team use only.

## BLUETOOTH INSTRUCTIONS

Play Mobile Music/Bluetooth speaker:

Turn on Bluetooth of mobile, then select Bluetooth device of massage chair (NUOVABLAC). Once paired, it can act as speaker when mobile phone is playing music. (Remarks: No Password)

# Cleaning And Maintenance

## Cleaning of the synthetic leather

Wipe the synthetic leather with a soft dry cloth.

- **Do not clean the product with chemicals such as thinners, gasoline and alcohol.**
- **When using a leather maintenance product (cleaning cloth) sold on the market, follow its directions for use.**
- **If the synthetic leather is very dirty, wipe it with the method below.**
  1. Put a piece of soft cloth into water or 3% to 5% neutral detergent contained hot water and wring it out.
  2. Wipe surface of the synthetic leather with the soft cloth.
  3. Wipe the detergent with a piece of cloth once soaked in clean water and wrung out.
  4. Wipe with a piece of wrung soft cloth.
  5. Have the synthetic leather take natural air drying.
- **If it is difficult to remove the stains on the synthetic leather, soak a piece of melamine foam bought from the market into a neutral detergent and use it wipe the product.**
- **Do not dry the surface by a hair dryer**
- **Surface of the synthetic leather may be dyed by fabric colors; therefore, be careful when wiping the product with denim or colored cloth.**
- **Keep these positions from long-time contact with plastics to avoid fading.**
- **Synthetic leather may discolor, so the position in contact with the hair dye used should be covered by a towel.**

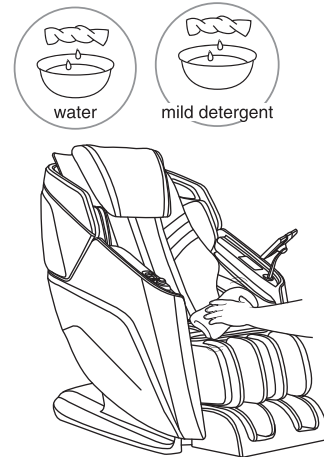

## Cleaning of the plastic parts

**1** Put a piece of soft cloth into water or neutral detergent contained hot water, wring it out and wipe the plastic parts.

- Do not clean the product with chemicals such as thinners, gasoline and alcohol.

**2** Wipe with a piece of cloth once soaked in clean water and wrung out.

- Wring the cloth out before using it to wipe the remote controller.

**3** Have the plastic parts take natural air drying.

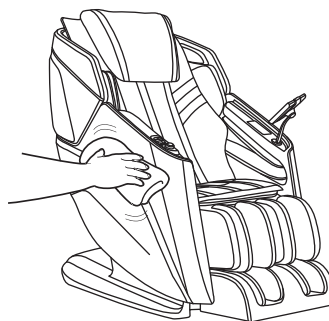

## Questions and answers (Q&A)

**Q** Can persons paying frequent visits to hospitals because of diseases use the product?

**A** **These persons should consult physicians before using the product.**  
 Massage is the so-called "touch-pressure stimulation": Muscles are compressed to relieve their tension and promote hemokinesis. Some diseases may get worsened because of massage. Thus, consult the attending doctors before using the product.

**Q** How about the body height requirement for use of the product?

**A** **The body height requirement differs with the specific body type. See the rough reference below when using the product.**

If a person shorter than 145 centimeters or taller than 185 centimeters uses the upper body massage function and the Lower Leg/Foot massage function of the product at the same time, it will be possible that his soles will have poor contact with the foot massage section or that his knees will need to be bent.

For a taller person with knee bending when using the product:

Select method **A**

**A** Tilt the backrest and lower the Lower Leg/Foot massage section.

For a short person difficult to touch the foot massage section:

Select method **A**

**A** Raise the backrest and lift the Lower Leg/Foot massage section.

**Q** Are there any things needing special attention during moving?

**A** **Pay attention to the following things during moving.**

For convenience during moving, tilt backrest of the product till the lowest position.

During handling, do not sit on the product.

① Press ON button power on the product.

② Press **Backrest** to make the backrest completely tilt.

Press and hold on these two buttons until backrest and footrest stop



③ Turn off the power switch and pull out the power plug.

● If the original packing box is unavailable, make sure the power line is not wound on the product, wind it and place it on the seat surface. When handling the product, keep the power line from falling off and rubbing with ground.

● If the original packing box is unavailable, properly keep other packing auxiliary materials and wrap the product with them to avoid scratch and vibration during handling.

**Q** Where is serial number of the product?

**A** It is on back of the main body.

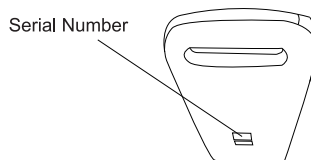

**Q** I care about the sounds the product makes when being used.

**A** It is caused by the core structure.

**Q** Does it matter if the massage wheels have different massage intensities?

**A** **This phenomenon possibly exists during massage because of the core structure.**

To simulate the most natural massage effect, the product is designed with a core structure allowing alternate back massage by a left massage wheel and a right massage wheel. During massage, the massage wheels possibly have slightly different positions on the back. That's why you have that feeling. It is not a fault.



**Q** The acupressure force is too large.

**A** **Set the air bag intensity to be "1" through the Air Bag button. You can also lower the Lower Leg/Foot massage section to reduce the acupressure force on the feet.**

# Troubleshooting

**After a fault happens, inspect and try the corresponding method below.**

If the fault still exists after that, contact the shop from which you bought the product.

Fault	Cause and elimination method
<p><b>The massage wheels stop during use</b> (The product beeps and all icons and buttons on the remote controller flicker and then go out.)</p>	<p><b>For safety, the massage wheels will possibly stop upon a too large external force during use.</b> If all marks and buttons on the remote controller begin to flicker, it suggests an extreme abnormality. In this case, turn off the power switch and turn it on about 10 seconds later. If the massage wheels stop again, adjust your sitting posture and do not lean on the backrest completely. (Users, particularly those heavier than 100 kilograms, should follow relevant precautions.)</p>
<p><b>The product cannot tilt, or the footrest cannot be raised or lowered</b> (The product beeps, the running light on the remote controller goes out and the product stops)</p>	<p><b>For safety, the product will stop upon an obstruction or a too large force.</b> If all contents and buttons are flickering and the backrest or the footrest has stopped, turn off the power supply and turn it on about 10 seconds later and then operate the product.</p>
<p><b>The massage wheels cannot reach the shoulders or the neck</b></p>	<p>If the head is not in contact with the headrest, or the back is not in contact with the backrest, the shoulder position in body type detection will possibly be lower than the actual position. Sit in the deepest position of the product, lean your head on the headrest and operate from the beginning again.</p>
<p><b>The left and right massage wheels have different heights (intensities)</b></p>	<p>It is not a fault but a normal phenomenon because the product is provided with a massage core allowing alternate beats of the massage wheels.</p>
<p><b>The product cannot run at all.</b> ● Upper body (the neck to the waist) massage ● Lower leg/foot massage</p>	<ul style="list-style-type: none"> <li>● The power line is disconnected.</li> <li>● The power switch is not turned on.</li> <li>● No program is selected after  on the remote controller is pressed.</li> </ul>
<p><b>The product cannot cool down even if the heating function is disabled.</b></p>	<ul style="list-style-type: none"> <li>● Due to the heater structure, the product will still feel warm shortly after heating because of the residual heat.</li> <li>● If a single part is continually massaged even after the heating function is disabled, you will feel increasingly warmer.</li> </ul>
<p><b>The power supply cannot be connected even if  is pressed again after the massage</b></p>	<ul style="list-style-type: none"> <li>● The program will terminate about 5 seconds after the massage has ended. Press  at least 5 seconds after all the movements have stopped.</li> </ul>
<p><b>The product is damaged</b></p>	<p>To avoid accidents, contact an authorized service center.</p>
<p><b>The power line or the power plug has abnormal heating</b></p>	



# Troubleshooting

## The sounds and feelings you care about in use of the product

**You will hear or have the following sounds or feelings when using the product. It is not abnormal phenomena but results of the product structure.**

- Sound when the stretching massages are retracted
- Sound and feeling when the massage wheels rub patterns on the fabric
- Sound of movements such as kneading and beat
- Friction sound of the running massage wheels
- Sound of up-down movement
- Sound of the conveyor belt
- Motor sound
- Sound of the squeezing massage wheels when they begin to stretch
- Sound when a person is sitting on the seat
- Friction sound between the armrests and the back cushion when the backrest is tilting
- Friction sound between the massage wheels and the fabric
- Sound of the inflator pump during Air Bag massage
- Sound of air exhaust during Air Bag massage
- Running sound of the solenoid valve at bottom of the product during Air Bag massage.
- Swing of the footrest
- Sound when the shoulders are stretched or moved
- Running sound of the air bags
- Sliding sound of the foot massage section
- Friction sound between the back cushion and the back cover leather when the backrest is tilting

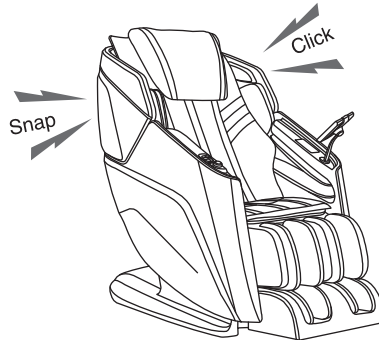

**If the sound is loud, it is also possible that the product has failed.**

- In this case, have the product inspected and repaired by an authorized service center.

### **Warning**

- **Do not refit, disassemble or repair the product without permission.** Otherwise fires, abnormal movements or personal injuries may happen.

### **Warning**

- **In the case of any abnormality or fault, stop the product immediately and pull out the power plug to avoid fuming, fires and electric shocks.**  
< Abnormality and fault examples >
  - The product fails to work after the power switch is turned to the ON position;
  - After the power line is moved, the product is discontinuously powered on;
  - In use, the product gives off a burning smell or an abnormal sound;
  - The product is deformed or abnormally heating→ In any of these abnormalities and faults, have the product inspected and repaired by an authorized service center immediately.

## Product Specifications

Power supply		AC220-240V~,50/60Hz
Power consumption		120W
Upper body massage	Range of massage (up-down direction)	Approx. 97cm
	Massage speed	Kneading:Approx.21 times/min-Approx.37 times/min
		Beat:Approx.422 times/min-Approx. 703 times/min
		Moving speed:Approx.43mm/s
Adjust angle		Backrest: Approx. 124°~157° Footrest: Approx. 92.5°~ 115°
Automatic power-off		Approx. 15 minutes(automatic power-off)
Dimension	When it is not tilting ( L x W xH)	Approx. 1550mm x 780mm x 1200mm
	When it is tilting ( L x W xH)	Approx. 1800mm x 780mm x 920 mm
Weight		Approx. 76 Kg
Dimensions of packing box ( L x W xH)		1280x815x1210mm
Weight(including the packing box)		Approx. 98 Kg
Operating Conditions		Ambient temperature:Approx.0°C~35°C Relative humidity:Approx.20%~80%
Storage Conditions		Ambient temperature:Approx.-5°C~35°C Relative humidity:Approx.20%~80%
Maximum body weight of user		Approx. 120Kg

For a user heavier than 100 kilograms, the product may have bigger noise and its fabric housing may be worn quicker.

# 安全說明

## 警告!

此按摩椅必須使用與插頭相配的插座。不正確的接地將會導致觸電危險的發生。

請不要擅自改裝插頭或插座，務必委託專業的技術人員進行檢查。

使用電器產品時，為減少觸電、灼傷、火災、或人員傷害的危險，應遵守基本安全預防措施，包括以下內容：

在使用前請閱讀所有的使用說明。

1. 務必使用與插頭相配的插座。
2. 一定要確保插頭完全插入插座內，以減少短路或火災危險。
3. 在使用後或清潔前，請務必及時拔掉插頭。
4. 請勿在高濕度的環境下使用本產品。
5. 請勿在室外或陽光直射的地方存放或使用本產品。
6. 如果在使用過程中突然停電，請立即將開關撥至「O」的位置，且拔掉插頭，以免來電時損壞本產品。
7. 當電源線潮濕或損壞時請勿使用按摩椅。
8. 請勿用濕手插入和拔掉插座，以免發生意外。
9. 當小孩、傷殘人士、行動不便者在按摩椅附近或使用按摩椅時，一定要有人在場看護。
10. 只能將本產品用於本說明書中闡述的用途。
11. 不要使用非 OGAWA 推薦的附件。
12. 在使用過程中請勿坐在按摩椅小腿上，以免導致意外。
13. 請勿試圖站在扶手或靠背上，以免按摩椅發生傾倒從而導致意外。
14. 按摩過程中請勿進入睡眠狀態。
15. 請經常保持按摩椅清潔，避免將其他物體插入按摩椅的縫隙中。
16. 請勿直接透過拉扯電源線來移動按摩椅。
17. 請確保當降低小腿或靠背時，其下方無其他物體，特別是小孩。
18. 請在每次使用前，檢查按摩椅靠背絨布等處是否有異常裂縫。如有異常，請勿使用並即時聯繫 OGAWA 售後服務中心。
19. 本產品僅為居家使用而設計。
20. 當您無法確定自己是否能使用按摩椅時，請先諮詢醫師。

## 安全說明

21. 為避免因使用此按摩椅而導致不適或傷害，以下人士在使用本產品前應諮詢醫師：
  - 患有惡性腫瘤者
  - 患有心臟病者
  - 孕婦、產婦或月經期者
  - 需要安靜休息者
  - 正在接受治療者
  - 有背部疾病者，脊椎異常或扭曲者
22. 如在使用過程中覺得疼痛，請立即停止使用；如果在使用過程中受到損傷，請立即就醫。
23. 本產品僅為家庭提供舒適的按摩享受，並非專業的按摩醫療機械，因此不能代替專業的治療。
24. 建議每天使用按摩椅的時間為 30 分鐘，按摩同一部位時間不宜超過15分鐘，否則過度按摩會導致適得其反的效果，而且長時間使用會導致按摩椅過熱並縮短產品使用壽命。
25. 請勿在噴氣體溶膠或輸氧的環境中使用本產品。
26. 12歲或以下兒童不適用本產品，如果兒童不受監督，不能進行產品的清潔和用戶維護。
27. 如果電源線損壞，必須使用 OGAWA 或合法代理商所提供的專用電源線。
28. 使用過程中若施加過大的外力，為安全起見，機芯會自動停止以保護。當出現該情況時，先切斷整機電源，10秒后再接通電源進行操作。特別是體重超過100KG的用戶，使用時要特別注意。
29. 該設備具有加熱表面，對熱不敏感的人一定要小心使用設備
30. 此設備可以讓年齡從8歲以上兒童，肢體，感官或心智能力有缺陷，或者缺乏經驗知識的人使用，如果他們被監督，或者有經過有關使用本產品安全的方式和理解其危害性的指導。

## 保修權限

1. 本保修權限不可轉讓。
2. 本保修服務僅對在 OGAWA 購買的產品有效。
3. 當要求保修服務時，請出示購買證明（正本收據）。
4. 所有保修項目，包括但不限於這些健身及適銷性的保修項目有效期限需視保修政策而定。
5. 因錯誤使用、處理不當以及未經授權私自改裝和維修產品而導致的損壞，不屬於保修範圍。
6. 此保修範圍不包括不屬於產品本身的附件。
7. 此保修範圍不適用於租憑、交易、商業、機構或其他非住宅用戶。
8. 此保修範圍內所涉及的維修服務需經過 OGAWA 授權，且必須由授權的技術人員維修。
9. 若需更換的維修附件缺貨，OGAWA 有權採用替代配件進行維修。

## 功能特點

NUOVABLAC 按摩椅融合了負離子、音樂療法、7英寸液晶觸摸屏控制器等多項最新技術。它提供了適當的氛圍，通過喚起寧靜的心態并幫助您消除煩惱來緩解壓力和擔憂。

1. 舒適而現代的設計提供簡約和美感，巧妙地適合任何空間。
2. 負離子療法不僅能夠淨化空氣，而且有益于人體健康。
3. 在按摩的同時享受音樂療法有助于培養情緒平衡并使您的心靈平靜。
4. 7寸液晶觸摸屏控制器，讓您輕鬆掌控按摩椅，觸手可及。
5. 配備12種豐富的自動按摩程序，以滿足您的喜好。
6. 對您的肩膀、手臂、腿部和腳部進行全面的全身氣壓按摩。
7. 背部舒緩熱療可改善血液循環，有助于促進愈合和減少炎症。
8. 足部滾輪進行指壓按摩，施加壓力并對應腳部的各個穴位。
9. 3級零重力位置有利于放松和緩解壓力。
10. S+L軌道提供從頸部到臀部的全身背部按摩。

## 產品部件

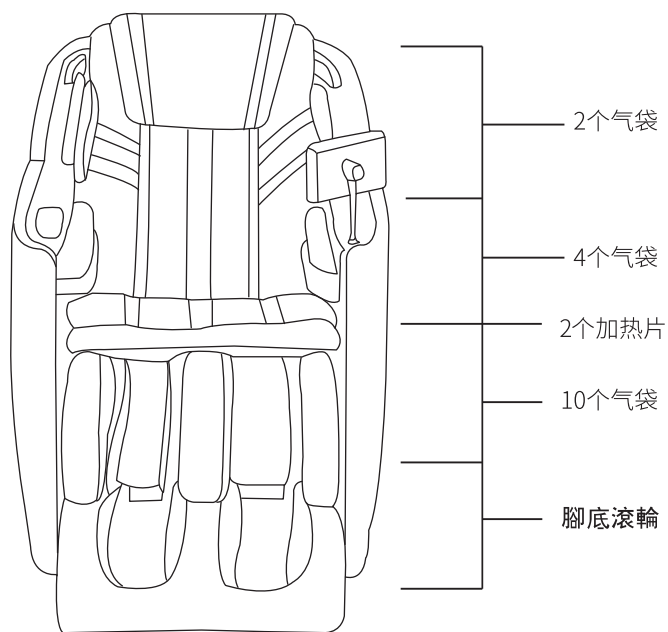
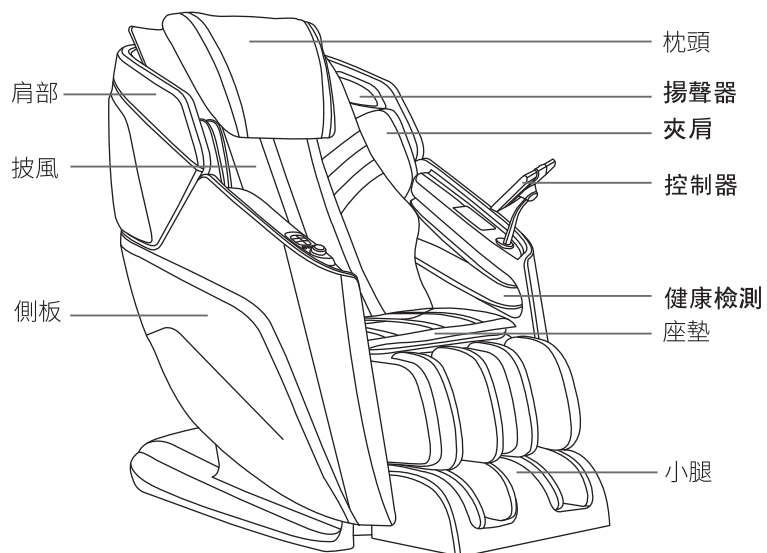

重要提示 - 由于產品質量的提高，  
產品圖片或内容描述可能會略有不同。

# 控制器

## 控制器說明

按下“電源開關鍵”開始按摩。



⚠ 請注意本機使用220V~電壓，使用其它電壓將可能造成內部電子零件損壞。

## 快捷鍵說明

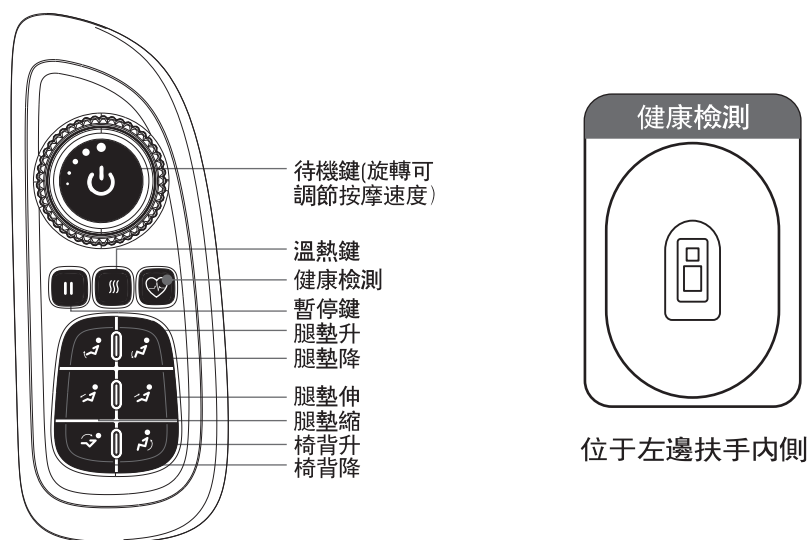

快捷按鍵 (位于右側扶手)

待機鍵	長按此鍵可開啟或關閉按摩椅，旋轉可調節按摩速度。
暫停鍵	長按此鍵可暫停按摩。
溫熱鍵	長按此鍵可開啟溫熱功能。
健康檢測鍵	長按打開健康監測功能。(使用前請將您的手指插入健康監測設備)
椅背升/椅背降	長按可調節椅背升降。
腿墊升/腿墊降	長按可調節腿墊升降。
腿墊伸/腿墊縮	長按可調節腿墊伸縮。



# 操作說明

## 控制器說明

### 1. 基本按鍵

按鍵	名稱	功能
	關閉	觸按此鍵可停止按摩并關閉屏幕。
	主頁	觸按此鍵可返回主頁。
	暫停	觸按此鍵可停止當前按摩并進入倒計時。
	重新開始	觸按此鍵可恢復以前的按摩功能并進入倒計時。
	返回	觸按此鍵可返回上一頁。
	調節	觸按此鍵可進入調節頁面。
	氣壓按摩	觸按此鍵可進入氣壓按摩頁面。

# 操作說明

## 2. 主頁菜單

按鍵	名稱	功能
 自動	自動	觸按此鍵可從12個自動按摩程式中進行選擇： 「暢快按摩」，「全身舒緩」， 「深層解壓」，「夜晚助眠」， 「氣血循環」，「泰式按摩」， 「老人保養」，「脊椎重點」， 「女王美體」，「男士健體」， 「肩頸重點」，「腰臀重點」。
 手動	手動	觸按此鍵可進入手動按摩程式頁面，選擇所需強度的首選按摩功能，全面定制按摩。
 調節	調節	觸按此鍵可進入「零重力姿勢」與「按摩強度」調整頁面。
 設置	設置	觸按此鍵可進入系統設置頁面，查看定時時間及其他選項。

## 操作說明

### 3. 自動按摩程式



按鍵	名稱	功能
	暢快按摩	暢快按摩是針對長時間辦公和出差人群設計的職場專屬按摩程式，可舒緩肌肉，調理身體。
	全身舒緩	全身舒緩程式包括輕柔「指壓」，「捶打」與「拍打」等按摩手法，可緩解和放鬆全身肌肉。
	深層解壓	深層解壓程式包括強力「指壓」，「捶打」和「拍打」等按摩手法，適合在劇烈運動后放鬆肌肉，特別是促進身體循環系統，改善運動后的肌肉恢復。



	<p>夜晚助眠</p>	<p>夜晚助眠程式旨在提供溫和按摩，非常適合深度放鬆。這是一個有助於提高午休時間和睡眠質量的程式。溫和地按摩身體部位，從重到輕，從輕到無，有助於逐漸舒緩疲憊的身體。此程式具有前後擺動功能，帶您進入夢幻空間的擺動狀態和徹底放鬆，適宜睡前使用。</p>
	<p>泰式按摩</p>	<p>此按摩程式將通過輕輕「拍打」，「揉捏」，「滾動」和「氣壓」的組合來拉伸您的小腿肌肉和腿筋。此程式的設計源自泰式按摩，身體的有力支撐與伸展可以有效地拉伸背部和腿部，是放鬆疲勞肌肉和增加體力的最佳選擇。</p>
	<p>氣血循環</p>	<p>全身輕柔按摩手法包括「揉捏」和「溫熱」，以促進氣血循環，專為日常使用而設計。</p>

	全身舒緩	全身舒緩按摩程式手法以全身揉捶+捶打為主，專為運動后放松而設計。
	脊椎重點	脊椎重點按摩程式，主要針對你的整個背部，進行深層按摩，包括氣壓，以緩解腰椎疼痛的症狀。
	瑜伽按摩	以拉伸和放松為重點的按摩程式，設計用于輕柔伸展身體，提高靈活性，緩解肌肉緊張。
	腿部護理	溫和的按摩程式，設計用于愛護和恢復腳部活力。
	肩頸重點	全身按摩，主要針對頸部和肩部，緩慢按摩，結合舒緩熱量，緩解頸部和背部疼痛症狀。座椅靠背使按摩滾輪完全貼合肩部和頸部，可以有效緩解疲勞和僵硬。

	<p>腰臀重點</p>	<p>下半身按摩程式，主要集中在您的下背部、腰部和臀部，並進行深層按摩，包括氣壓按摩，以緩解全身疼痛。</p>
---	-------------	---

### 背部掃描檢測說明

每次通電時按摩椅都會進行身體背部掃描檢測，以便為用戶選擇自動模式，它旨在確保為每個人提供準確和個性化的按摩。接通電源后，慢慢地坐在椅子上，背部靠在椅背上，頭部靠在頭枕上，這樣按摩傳感器就可以檢測您的肩部高度和整個背部位置。

完成背部掃描檢測時，控制器會發出嘟嘟聲。當需要微調時，只需觸按右側的向上或向下鍵「」，「」，然後按即「」可開始按摩。應確保身體背部掃描檢測正確完成，以獲得最佳按摩效果。

\*背部掃描檢測完成后，將跳至按摩狀態頁面，無需進一步操作。

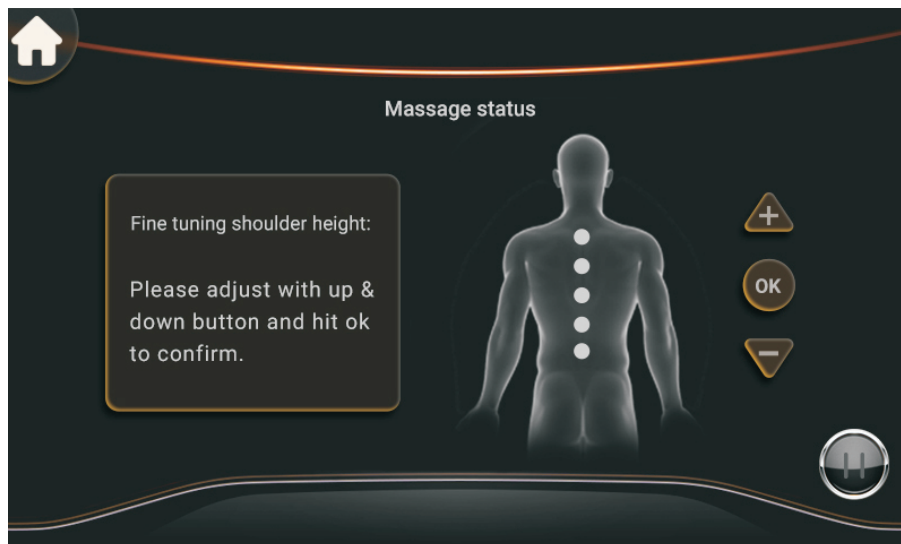

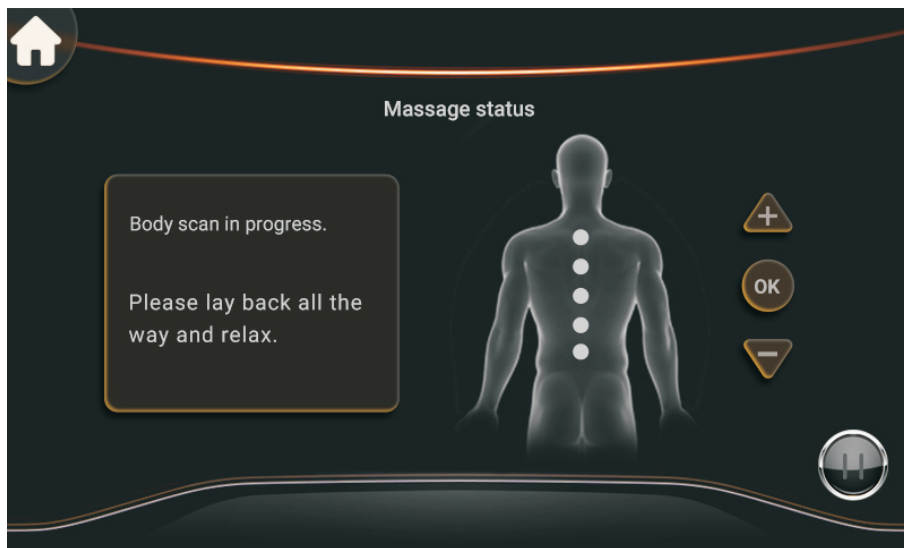

注意：  
 溫熱，腳底滾輪功能可以在任何自動模式下手動打開或關閉，請參閱下文。



## 操作說明

### 4. 手動按摩程式

背部功能：六種按摩功能手法可供選擇。

「揉捏」，「捶打」，「指壓」，「拍打」，「瑞典式」與「推拿」

- 觸按以上手法鍵可選擇手動按摩功能，默認進行中等強度的背部按摩。
- 手動設置模式不能與其他模式組合使用。
- 默認設置為中等寬度的特定部位按摩。
- 按摩速度和寬度可通過觸摸相關鍵進行調整。

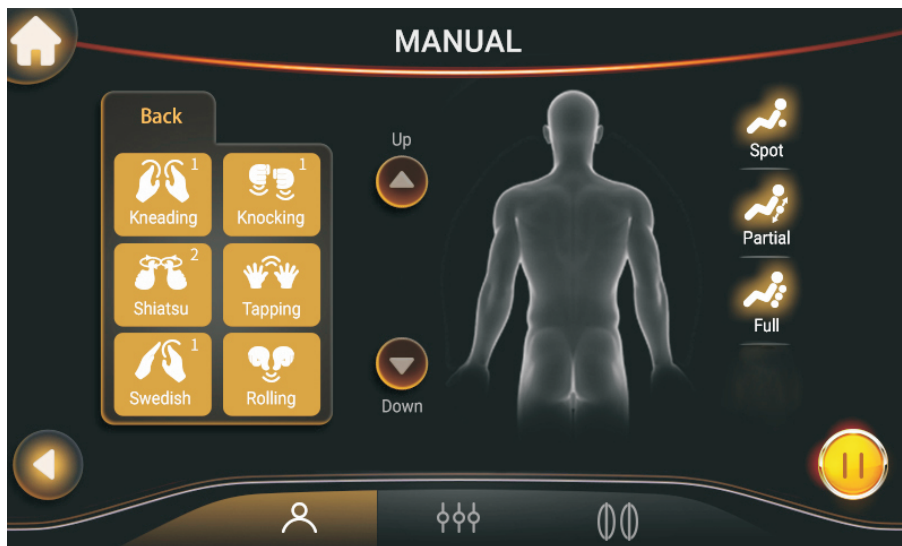



按键	名称	功能
 Spot  Partial	按摩輪定點 與區間按摩	觸按「定點」鍵可選擇按摩輪局部點按摩，同時原來的按摩模式繼續在最新位置運行。觸摸「區間」鍵可選擇按摩輪區間按摩，按摩輪以最新的按摩點位置為中心，並將向上或向下移動約8公分。僅在手動按摩模式下有效。
 Full	按摩輪全背 按摩	觸按「全背」鍵可選擇按摩輪全背按摩。
 Width	按摩輪寬度 選擇	每一次觸按「寬度」鍵都會改變按摩寬度，間隔按寬>中>窄變化。僅在手動按摩模式下有效。
 	按摩輪向上 或向下調整	觸按「向上」或「向下」鍵可調整按摩輪位置。

## 操作說明

### 5. 調節功能







零重力是基于美國國家航空航天局的太空艙松弛理論。使用靠背，座墊和腿墊，椅子將人體心臟和膝蓋放在同一水平面上，以降低血液循環壓力。不僅如此，所有的重力都可以分散到按摩椅上，從而減輕了心臟和脊椎的壓力。

## 零重力角度調節

按鍵	名稱	功能
 	腿墊角度調節	<p><b>腿墊上升</b> 長按此按鍵，腿墊將向上移動到頂部位置，松開此按鈕，腳墊停止移動。</p> <p><b>腿墊下降</b> 長按此按鍵，腿墊將向下移動到最低位置，松開此按鈕，腳墊停止移動。</p>
 	椅背角度調節	<p><b>椅背上升</b> 長按此按鍵，椅背將向上移動到頂部位置，松開此按鈕，椅背停止移動。</p> <p><b>腿墊下降</b> 長按此按鍵，腿墊將向下移動到最低位置，松開此按鈕，腳墊停止移動。</p>
 	腿墊伸縮調節	<p><b>腿墊伸出</b> 長按此按鍵，腿墊將向前伸出，松開此按鈕，腿墊停止移動。</p> <p><b>腿墊縮回</b> 長按此按鍵，腿墊將向后縮回，松開此按鈕，腿墊停止移動。</p>
	零重力角度調節	觸按此按鍵可調節零重力角度，可選擇「零重力模式1」，「零重力模式2」和「零重力模式3」等三種姿勢。

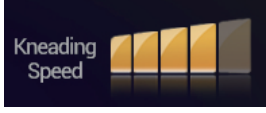
## 其他調節

按鍵	名稱	功能
	滾輪速度	慢 > 中 > 快 僅在手動按摩模式下有效 
	揉捏速度	5檔揉捏速度可供調節
	捶打力度	5檔捶打力度可供調節
	氣壓強度	5檔氣壓強度可供調節

## 操作說明

### 6. 氣壓按摩程式



按鍵	名稱	功能
 Full body	全身氣壓	觸按「全身」鍵可開啟全身氣壓按摩，再按一次為關閉。
 Shoulder	肩部氣壓	觸按「肩部」鍵可開啟肩部氣壓按摩，再按一次為關閉。
 Arm	手臂氣壓	觸按「手臂」鍵可開啟手臂氣壓按摩，再按一次為關閉。
 Waist	腰部氣壓	觸按「腰部」鍵可開啟腰部氣壓按摩，再按一次為關閉。
 Leg	小腿氣壓	觸按「小腿」鍵可開啟小腿氣壓按摩，再按一次為關閉。
 Foot	腳側氣壓	觸按「腳側」鍵可開啟腳側氣壓按摩，再按一次為關閉。

# 操作說明

## 7. 設置



### 音樂功能(藍牙說明)

手機播放音樂：先打開手機的藍牙功能，然後選擇按摩椅音箱藍牙設備（代號NUOVABLAC），待手機自動匹配好按摩椅音箱，即可實現通過按摩椅播放手機音樂功能。

注：藍牙無連接密碼。

# 清洗及保養

## 清潔合成皮革

### 使用柔軟的干布擦拭皮革。

- 切勿使用諸如稀釋劑、汽油、酒精等化學品清潔本機。
- 使用市面銷售的皮革保養品（抹布）時，請遵照其使用說明。
- 如果合成皮革特別髒，則通過以下方式擦拭。
  - 1、將軟布浸入水中或含3%至5%中性洗滌劑的熱水中，然後徹底擰干。
  - 2、使用上述軟布擦拭皮革表面。
  - 3、使用浸過清水且已徹底擰干的布料擦掉清潔液。
  - 4、使用擰干的軟布擦拭。
  - 5、使其自然風干。
- 難以去除污漬時，請將市面上購買的三聚氰胺泡棉進入中性洗滌劑中，然後用它擦拭本機。
- 不要使用吹風機吹干表面。
- 由於布料的顏色會染到合成皮革的表面上，因此在使用牛仔布和彩色布料擦拭本機時務必小心。
- 不要使這些部件長時間與塑料接觸，因為這會導致褪色。
- 合成皮革有變色的可能，所以在使用染發劑時，請將接觸的部分用毛巾覆蓋。

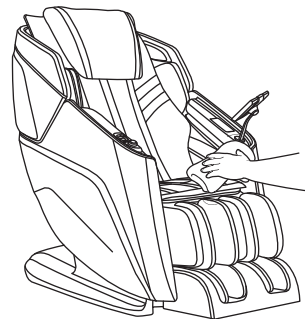

## 清潔塑料部分

### 1 將軟布浸入水中或含有中性洗滌劑的熱水中，擰干后，擦拭本機塑料部。

- 切勿使用諸如稀釋劑、汽油、酒精等化學品清潔本機。

### 2 使用浸有清水且已徹底擰干的布料擦拭。

- 擦拭遙控器前請務必擰干布料。

### 3 使其自然風干。

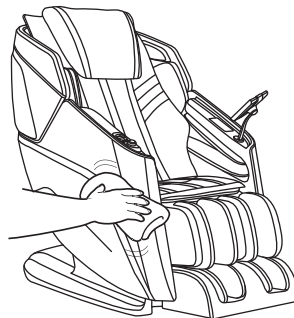

## 疑問解答 (Q&A)

**Q** 因為生病而經常出入醫院的人可以使用本產品嗎？

**A** 經常出入醫院的人，請在醫生商量的前提下使用本產品。

按摩即所謂「觸壓刺激」，即通過對肌肉進行壓迫，緩解肌肉緊張，促進血液流動。根據不同的病因，按摩有可能造成病情惡化，因此請務必在和主治醫生商量之後使用本產品。

**Q** 身高多少的人適合使用本產品？

**A** 根據體型的不同多少會有所差異。請大致參考下文使用產品。

- 身高小於145cm的用戶，及身高超過185cm的用戶同時使用上半身按摩和小腿、腳部按摩時，可能出現足底與腳部按摩部接觸不充分，或膝蓋彎曲的情況。

身高較高的用戶感覺膝蓋部位彎曲時

請選擇下述方法<sup>A</sup>

- <sup>A</sup> 放倒靠背，降低小腿、腳部按摩部位置。

身高較矮的用戶難以向下觸到足底按摩部時

請選擇下述方法<sup>A</sup>

- <sup>A</sup> 抬起靠背，升高小腿、腳部按摩部位置。

**Q** 搬家時，有什麼需要特別注意的地方？

**A** 請注意一下事項。

- 為了方便搬運，請先將按摩椅靠背傾斜到最低位置。
- 搬運時，人不要坐在座椅上。

① 按下開機鍵，接通電源。

② 按下  使靠背呈完全傾斜狀態。

請長按這個按鈕，直到靠背和小腿停止移動。



- 在有原裝紙箱的情況下，請先確認電源線未被纏繞在本機上，將電源線纏好放在座面上；搬運的時候，請注意電源線沒有掉落且未與地面發生摩擦。
- 在沒有原裝紙箱的情況下，為了防止機體劃傷和搬運中的震動，請妥善使用其他包裝輔材包裹本品。

**Q** 請問在哪里可以看到產品序列號？

**A** 在按摩椅主體背面的座面下。

產品序列號

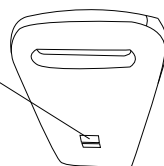

**Q** 有點在意按摩椅運作時發出的聲音……

**A** 按摩椅運作時產生的聲音，一般是由于機芯構造而發出來的。

**Q** 按摩中感覺左右兩邊按摩輪的按摩力度有差異，要緊嗎？

**A** 由于機芯構造，在按摩過程中，確有可能感覺左右按摩輪的力度有差異。

為了能夠模擬出最自然的按摩手法，本品機芯採用了允許左右按摩輪交替捶背的機芯構造。在按摩過程中，左右按摩輪接觸背部的具體位置可能稍有差異，從而導致了使用者產生左右兩側按摩力度有所不同的感覺。此時，本品本身並未發生故障。

**Q** 感到足底指壓過于用力……

**A** 使用氣囊按鈕將氣囊強度設置為「1」。另外，降低小腿、腳部按摩部，也可以減輕足底的指壓力度。



## 故障維修

發現故障后，首先檢查并嘗試一下方法。

如果在嘗試后，故障依然存在，請聯系銷售店。

問題	原因和處理方法
本使用本機過程中按摩輪停止 (按摩椅發出「嗶嗶」的聲音，遙控器上所有的顯示圖標和按鈕閃爍然后熄滅)	<b>在使用過程中，按摩輪遇到過大的外力時，處于安全考慮，按摩輪可能會停止移動。</b> 如果遙控器上的所有標記和按鈕開始閃爍，這種情況極為異常，請關閉電源開關，等待約10秒鐘，然後再次打開電源。 如果按摩輪再次停止，請調整自己的坐姿，不要使背部完全貼在靠背上。（應注意遵守相關注意事項，尤其在體重為100kg或以上的人使用時。）
不能傾斜 腿置臺不能升高降低 (發出「嗶嗶」的聲音，遙控器的運行指示燈熄滅并停止運行)	<b>如果本機遇到了障礙物或者在使用本機時用力過大，處于安全考慮，本機將停止工作。</b> 當所有顯示的內容及按鈕在閃爍時，且靠背或腿置臺已停止工作，關閉本機電源一次，約10秒鐘后再次打「開啓」電源，然後操作本機。
按摩輪沒有達到肩部或頸部的位置	如果頭部沒有接觸到靠枕，或背部沒有接觸到靠背，在體型檢測過程中肩部位置可能低于實際位置。坐在座椅的最深位置，將頭部靠在靠枕上，然後從頭開始重新操作。
左右按摩輪的蓋度（強度）不同	因為搭載了可進行按摩輪交互捶拍動作的按摩機芯，出現這種情況純屬自然，并非機體故障。
本機根本無法運行。 ● 上半身（頸部至腰部）按摩 ● 小腿和腳部按摩	<ul style="list-style-type: none"> <li>● 電源線連接已斷開。</li> <li>● 沒有打開本機電源開關。</li> <li>● 按下遙控器上的  按鈕后，沒有選擇任何程序。</li> </ul>
即使關閉溫熱功能，溫度也降不下來	<ul style="list-style-type: none"> <li>● 由于加熱器的結構，加熱后片刻依然會因為余熱而感到溫暖。</li> <li>● 關閉溫感功能，持續按摩同一部位，也會使體感溫度上升。</li> </ul>
按摩結束後，即使重新按下  按鈕，也無法接通電源	<ul style="list-style-type: none"> <li>● 按摩結束後大約需要5秒鐘程序才終止。當所有運作均已停止后至少等待5秒鐘，然後再按 。</li> </ul>
本機已受損	
電源線或電源插頭異常發熱	為防止事故發生，請務必與授權服務中心聯系。

## 故障維修

### 關於運行過程中本機發出的聲音和令人在意的感覺

在使用中會發生下述動作音、感覺，不過這是因按摩椅的結構而發生，并非異常。

- 按摩輪由「伸出」改為「收回」時的聲音
- 動作時按摩輪擦過面料上的皺紋時發出的聲音和感覺
- 揉按、捶拍動作等的動作音
- 按摩輪動作時的摩擦聲
- 上下運動時的動作音
- 傳送帶的轉動音
- 電機音
- 按摩輪從「擠壓」改為「拉伸」時的聲音
- 落座時的聲音
- 靠背傾斜時扶手與靠墊的摩擦聲
- 按摩輪與布料的摩擦聲
- 氣囊按摩運作時的充氣泵工作音
- 氣囊按摩運作時的排氣音
- 氣囊按摩運作時座椅下電磁閥發出的工作音
- 腿置臺的晃動
- 肩部伸展、動作時的聲音
- 氣囊的動作音
- 腳部按摩的滑動音
- 靠背傾斜時，靠墊與后蓋上皮革摩擦時發出的聲音

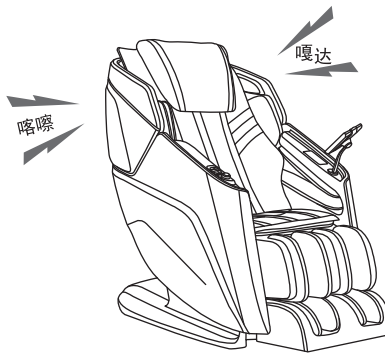

當聲音變大時，也有可能發生了故障。

- 此時，請委托授權服務中心進行檢查和修理。

#### 警告

- 請勿擅自改造本機。請勿自行分解或修理本機。否則可能導致起火、異常動作、人身傷害。

#### 警告

- 發生異常、故障時，立即停止使用，拔掉電源插頭。（否則可能冒煙、起火、觸電）  
<異常、故障事例>
  - 接通電源開關后可能不動作
  - 移動電源線，有時通電有時不通電
  - 運行中發出焦臭味、異常聲響
  - 按摩椅變形或者異常發熱→請立即委托授權服務中心檢查和修理。

 警告：除了修理技術人員之外，絕對不可自行拆解、修理和改動。  
有可能會導致火災、觸電。

## 產品規格

電 源		AC220-240V~，50/60Hz
消 耗 電 力		120W
上半身 按摩	可按摩範圍(上下方向)	約97cm
	按摩速度	揉捏約21次/分鐘~37次/分鐘
		敲擊約422次/分鐘-703次/分鐘
	移動速度約43mm/秒	
傾 斜 角 度		靠背:約124°~157° 小腿:約92.5°~115°
自 動 關 閉		約15分鐘(自動斷電)
尺 寸	未傾斜時 (高 x 寬 x 長)	約 1550mm x 780mm x 1200mm
	傾斜時 (高 x 寬 x 長)	約1800mm x 780mm x 920mm
重 量		約76Kg
包裝箱尺寸 (長 x 寬 x 高)		約 1280x815x1210mm
重量(含包裝箱)		約 98 Kg
使用環境		環境溫度:0°C~35°C 相對濕度:20%~80%
儲存環境		環境溫度:-5°C~35°C 相對濕度:20%~80%
用戶最大體重		約120Kg

對於體重100kg或以上的人士，產品運作時可能產生更大的噪音而且面料外罩可能磨損得更快。

## 聯系我們 Contact Us



**MALAYSIA**  
Healthy World Lifestyle Sdn Bhd  
No. 22 Jalan Anggerik Mokara 31/47  
Kota Kemuning, 40460 Shah Alam  
Selangor Darul Ehsan, Malaysia  
Tel : 1800 88 4688  
Fax: +603-5121 4386



**HONG KONG, CHINA**  
OGAWA Health Care International (HK) Ltd  
31/F, YHC Tower, 1 Sheung Yuet Road  
Kowloon Bay  
Kowloon  
Hong Kong  
Tel: +852 3465 6262  
Fax: +852 2410 0119



**SINGAPORE**  
OGAWA Health-Care Pte Ltd  
27 Tampines Industrial Avenue 5,  
T5 @ Tampines  
Singapore 528623  
  
Tel: +065-6846 8588  
Fax: +065-6846 7677



**VIETNAM**  
OGAWA Vietnam Co Ltd  
2nd floor, Petroland Tower,  
12 Tan Trao, Tan Phu ward  
District 7, Ho Chi Minh  
Tel: +84 8 54133 222/54133 223  
Fax: +84 8 5416 1736



**PHILIPPINES**  
O-Healthcare Solution Phil. Inc.  
2303, 4th Floor, G&A Building,  
Chino Roces Avenue Extension,  
Makati City, Philippines  
Tel : +632 889 0676 / +632 844 6851  
Fax: +632 812 0421

Ogawa is grateful  
to have received  
these awards:



PUTRA  
BRAND AWARDS 2010  
SILVER  
MALAYSIA'S MOST VALUABLE BRANDS

Ogawa Wellness Hubs : Malaysia . Singapore . Vietnam . Philippines . Indonesia . Myanmar . India . China .  
Hong Kong . Taiwan . Turkey . Pakistan . Mauritius . Russia . France . Canada . Thailand .  
Korea . Australia . Dubai . K.S.A . Nigeria . Egypt . Lebanon . Denmark . Sweden . U.S.A